

Montageanleitung Installation instructions Instructions de montage Montagehandleiding

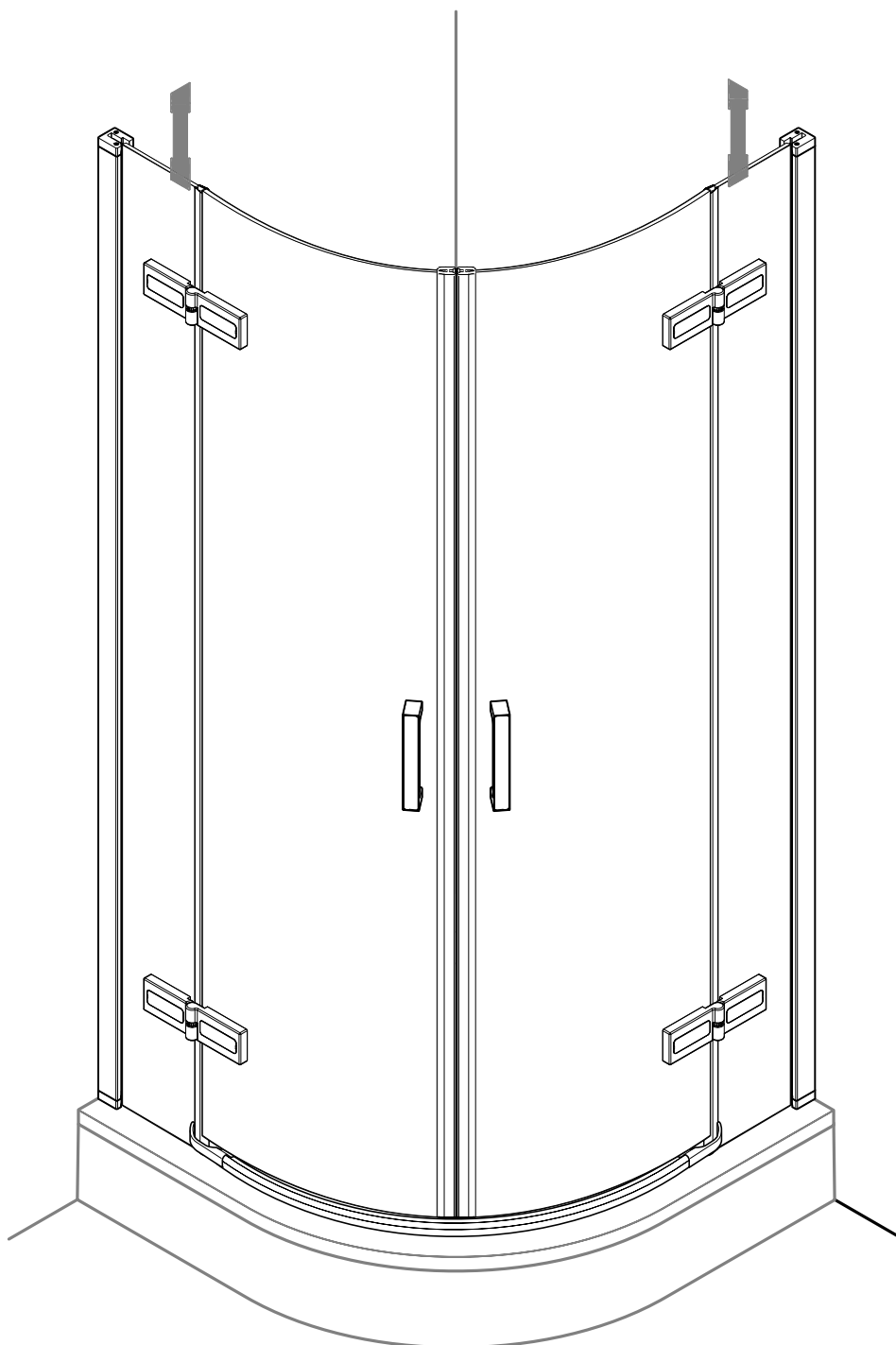

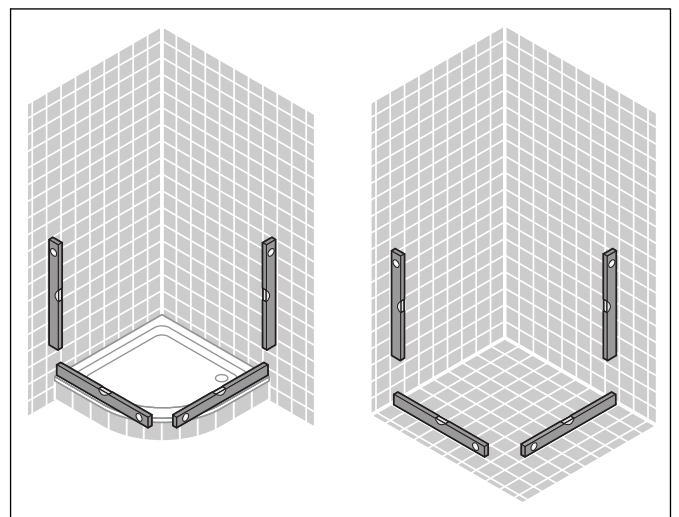

1

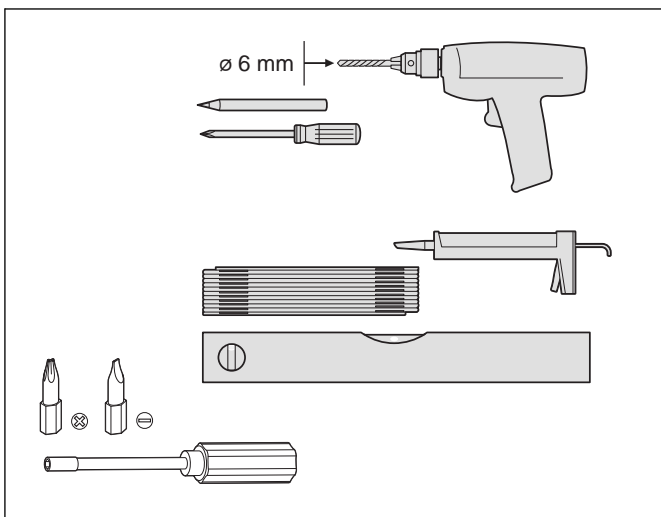
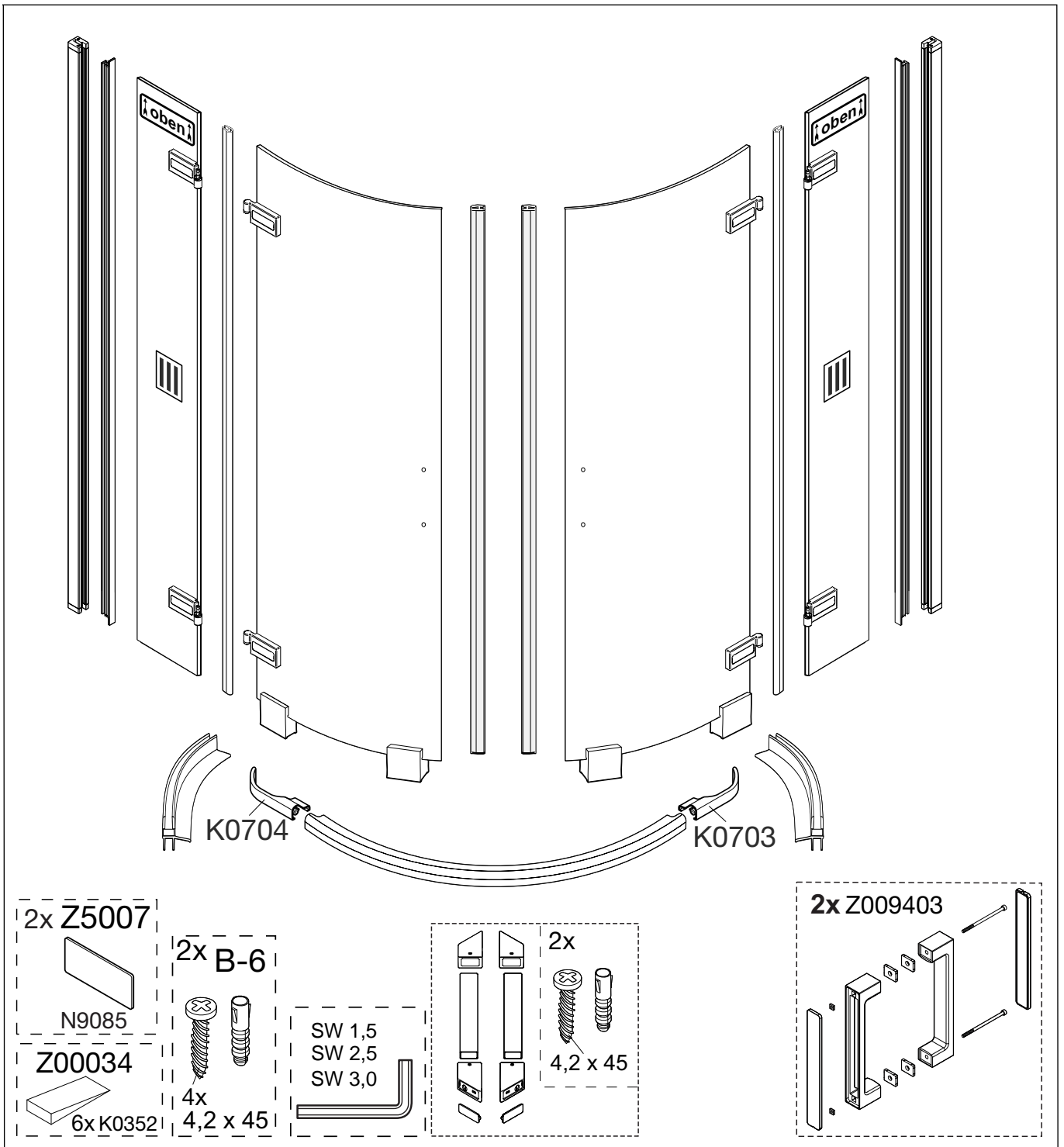
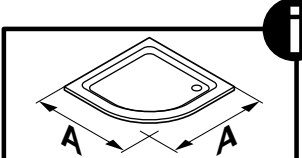

A	B
800	780-800
900	880-900
1000	980-1000
SOM	780-1300

a

b

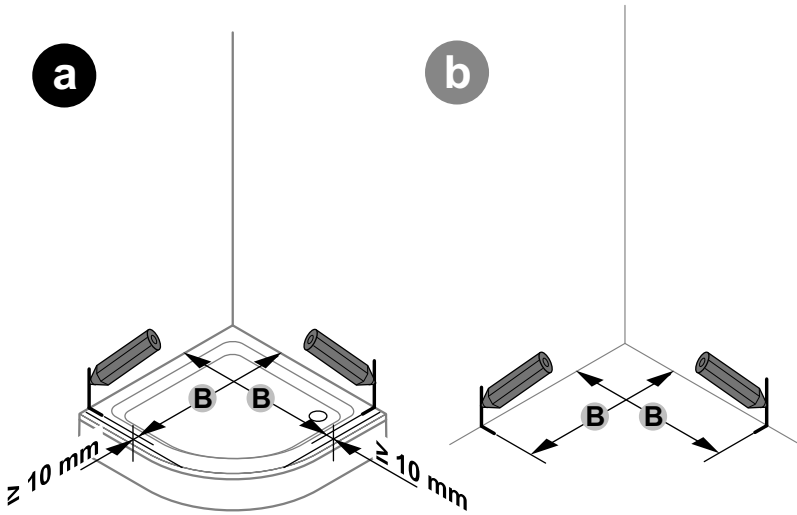

2

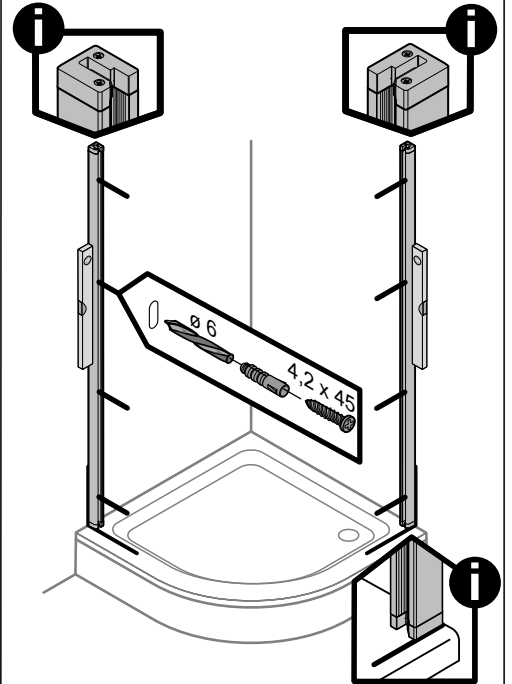

3

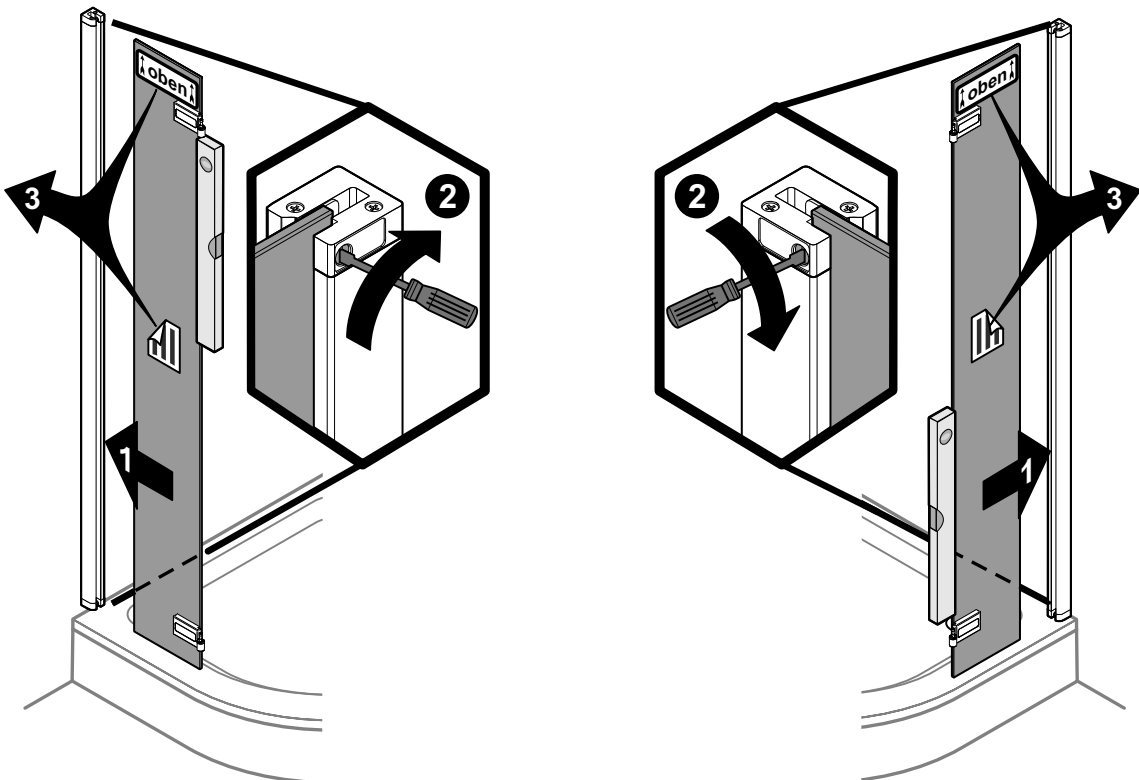

4

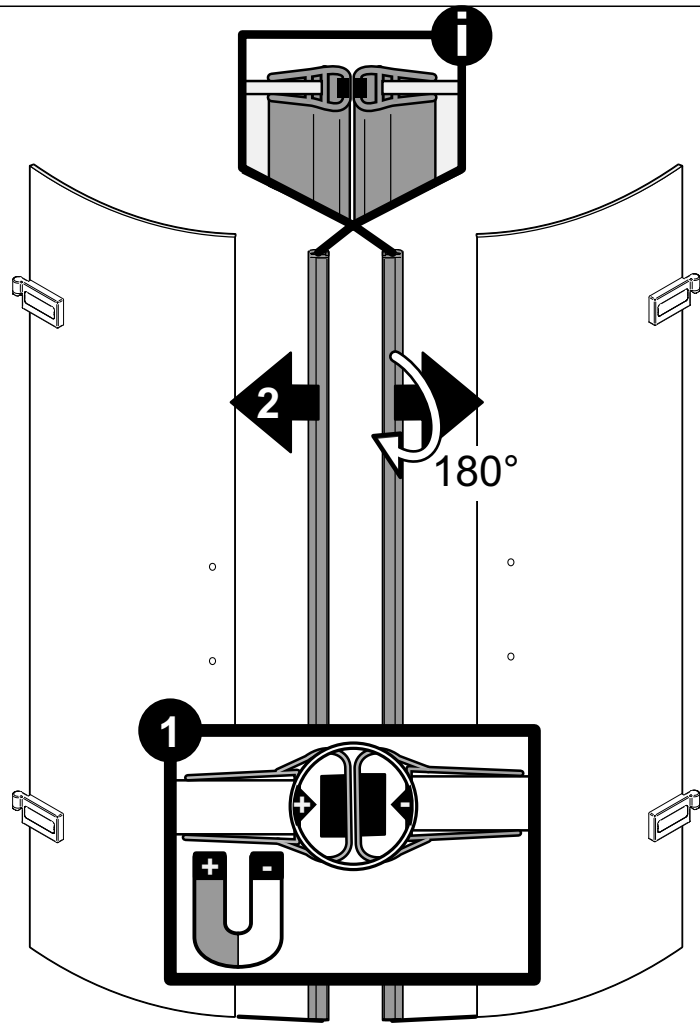

5

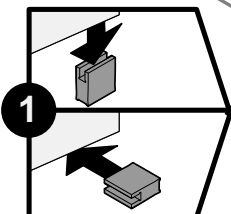
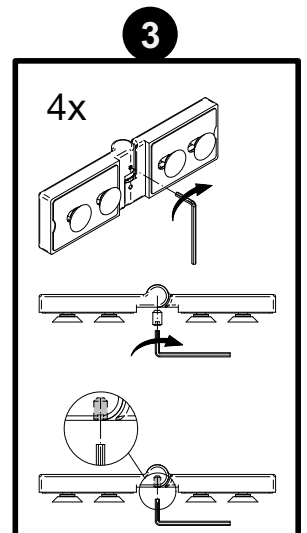
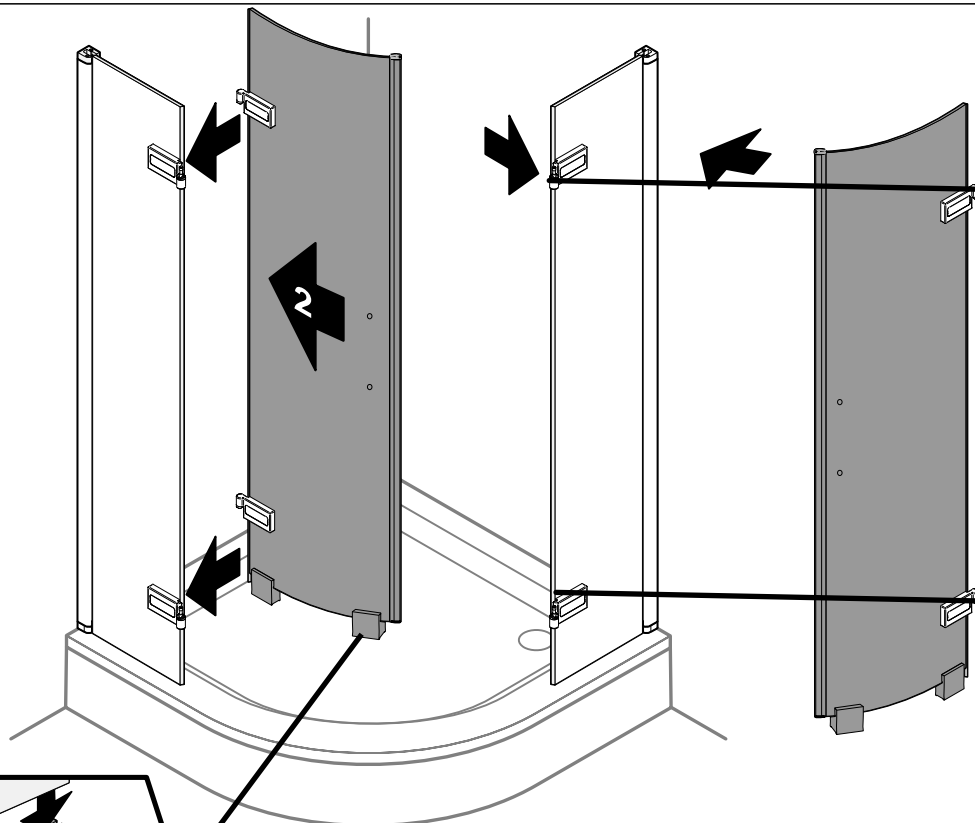

Bei Montage auf Fliesen!
 Assembly on joint of tile!
 Montage sur sol à l'italienne!
 Montage op tegelvloer!

6

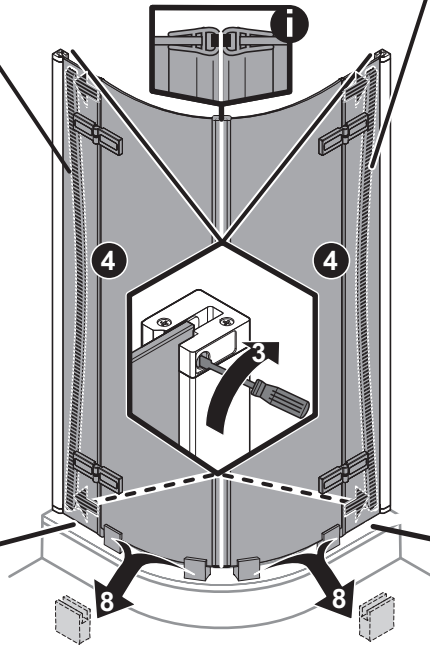
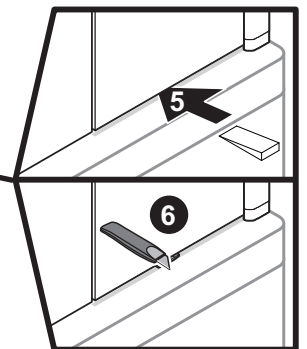
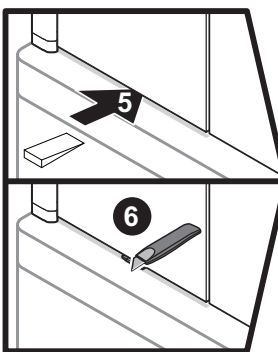
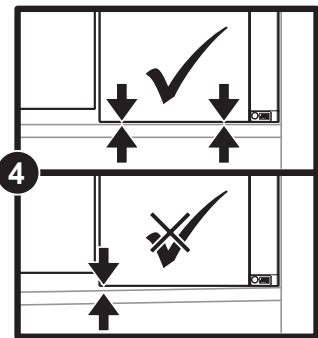
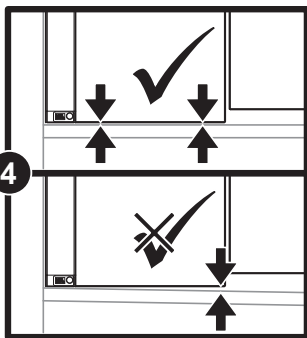
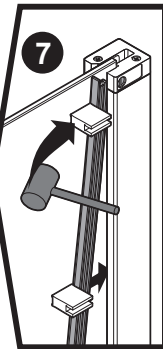
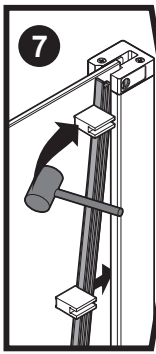
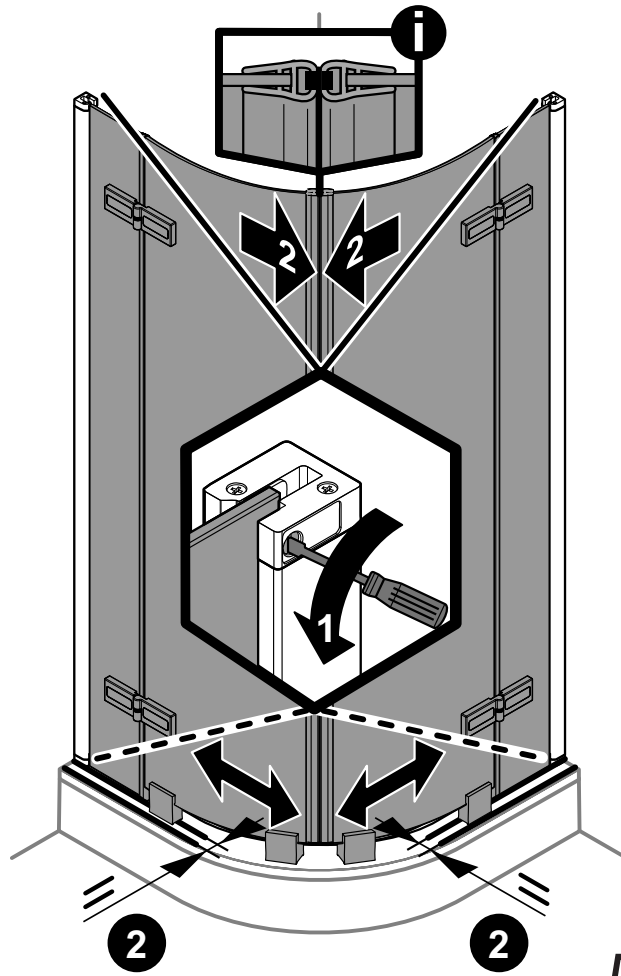

7

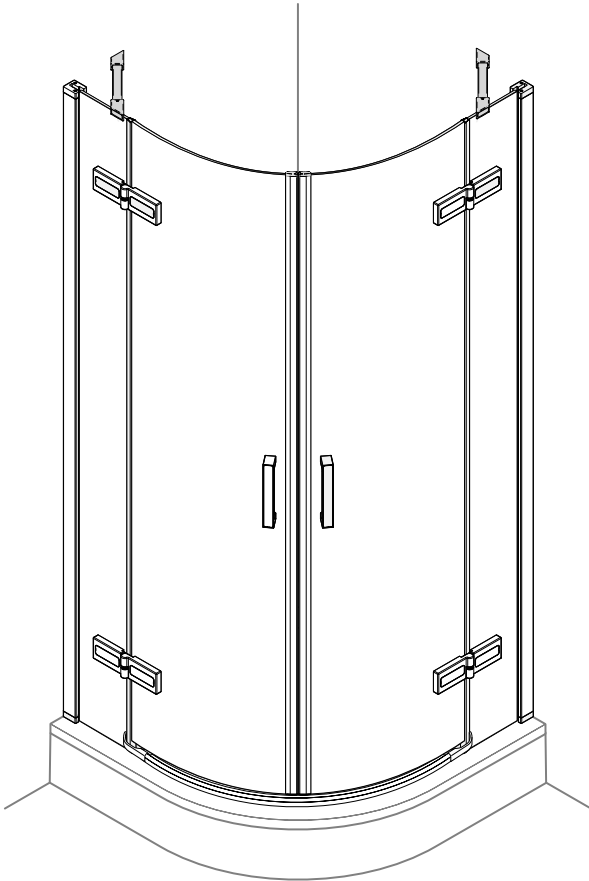

- Die Montage des Stabilisationsbügel entnehmen Sie dem Zusatzblatt.
- Please look into the additional sheet for the installation of the stabilizing bar.
- Veuillez regarder dans la feuille additionnelle pour l'installation de la barre de stabilisation.
- Voor de installatie van de stabilisatie stang zie aanvullende blad.

8

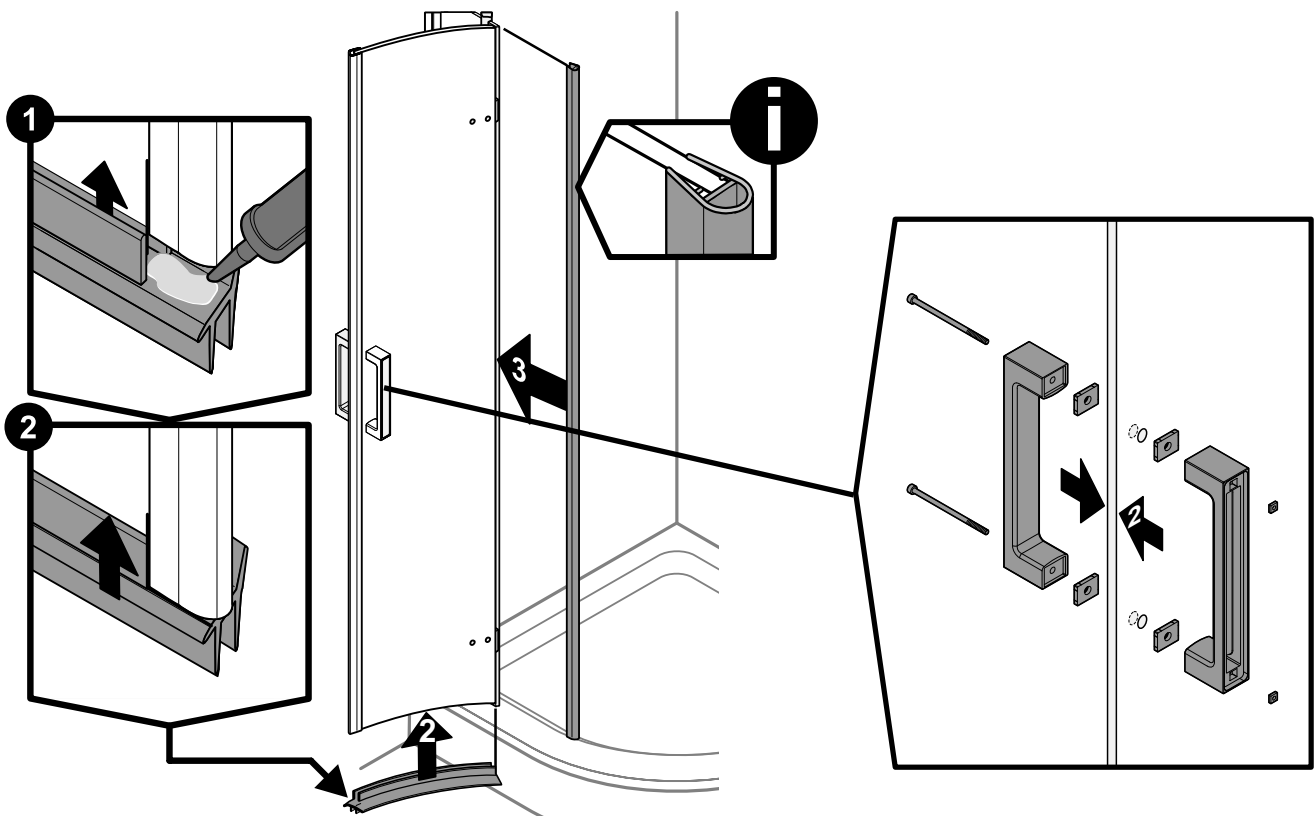

9

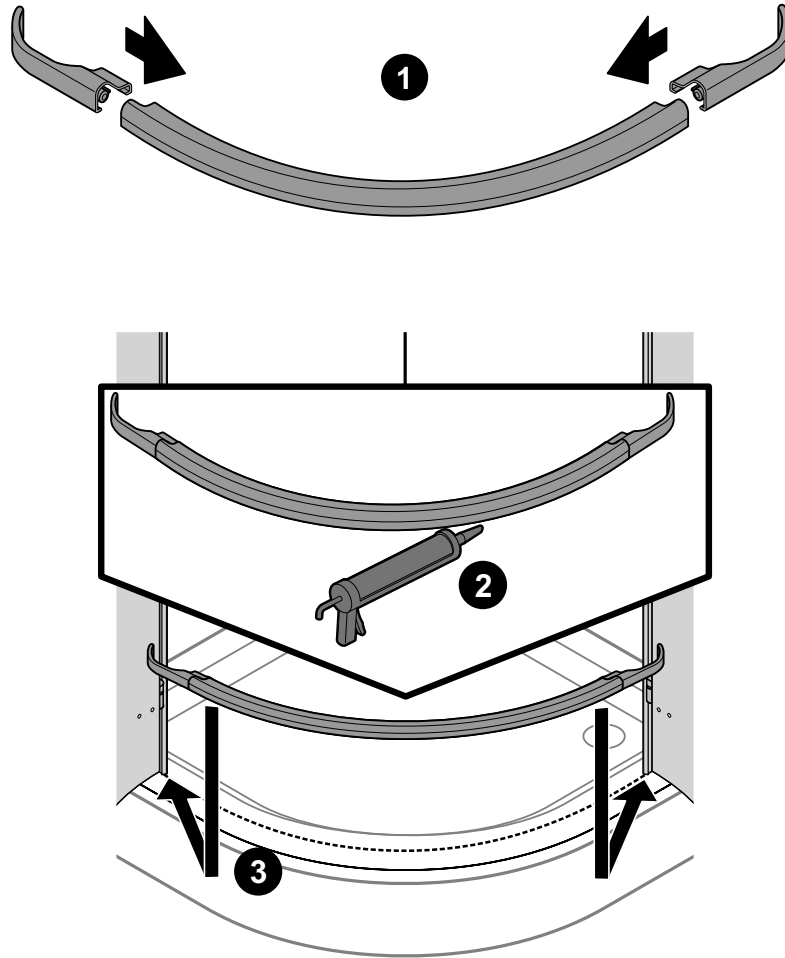

10

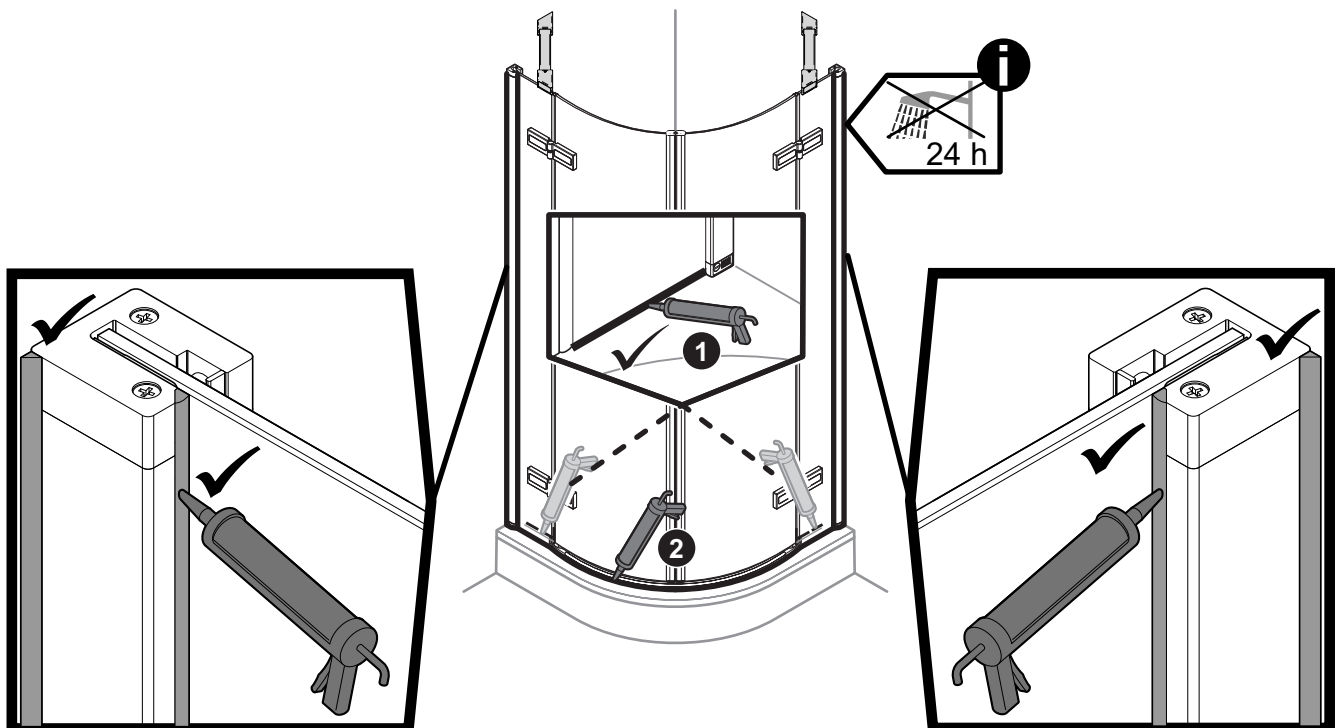

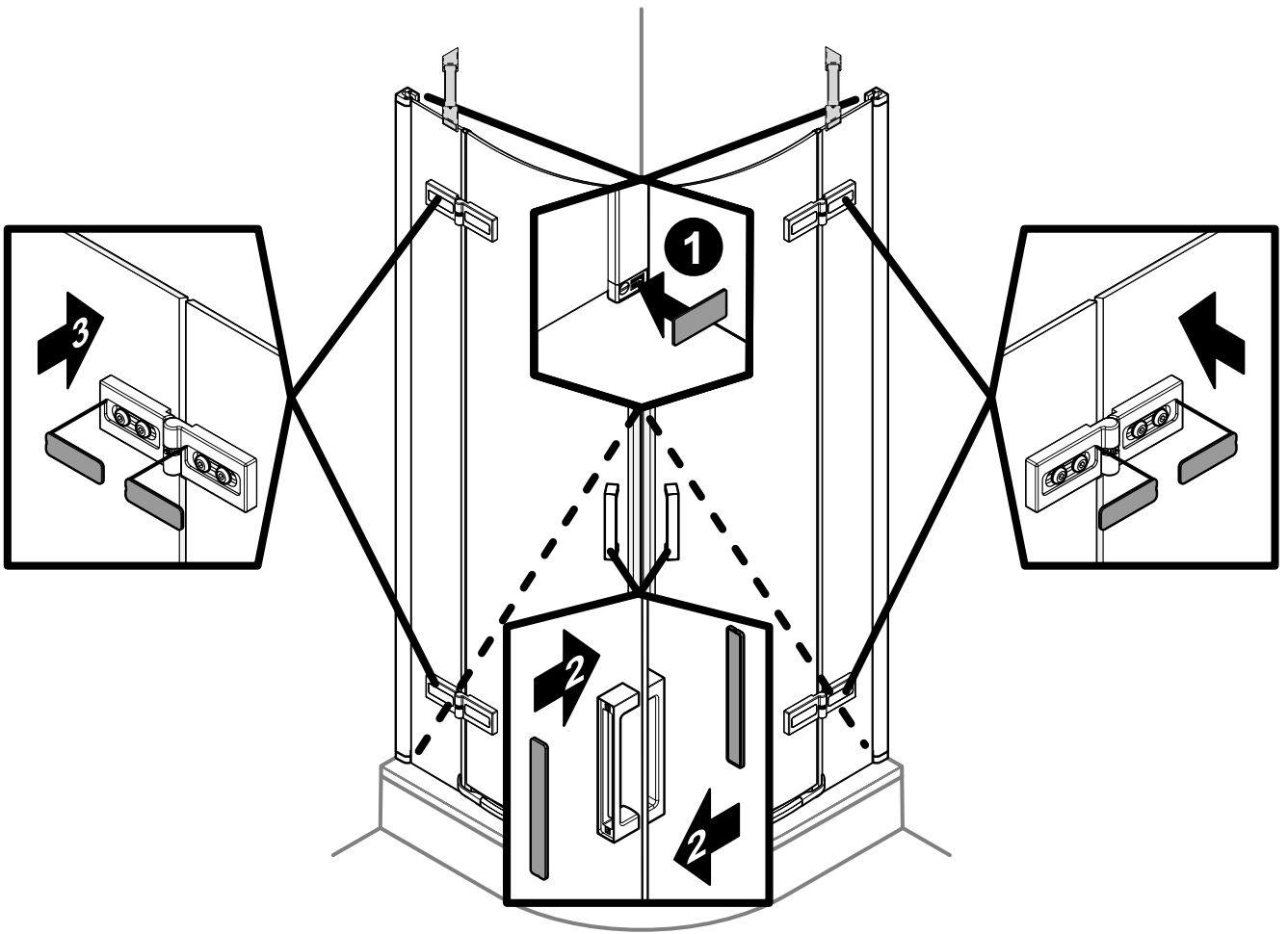

Notizen, notes, notities

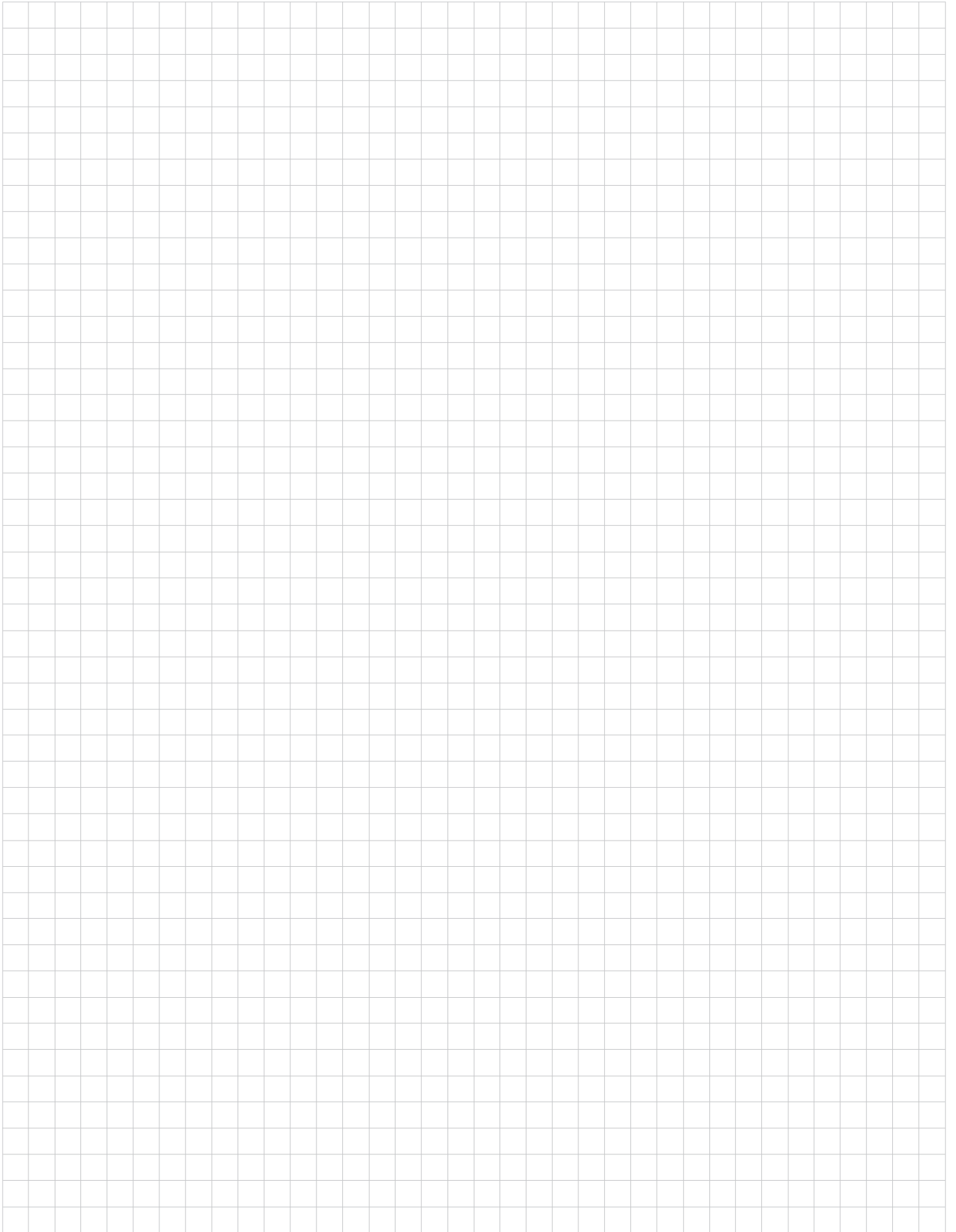

D Wichtiger Hinweis:
Duschcabinen bitte vor dem Einbau auf Transportschäden und Vollständigkeit prüfen, da Beanstandungen nach dem Aufbau nicht mehr anerkannt werden können.

GB Important information:
Please check the shower enclosure for transport damage and completeness before installation. Complaints made following installation cannot be accepted.

F Remarque importante:
avant de procéder au montage, vérifiez que le pare-douche est complet et qu'il n'a pas été endommagé lors du transport. Aucune réclamation ne pourra être admise après le montage.

NL Belangrijk:
Controleer voor het inbouwen of het douchescherm bij het transport beschadigd is en of het volledig is. Na het inbouwen kunnen klachten niet meer in behandeling genomen worden.

D Sicherheitshinweis:
Einscheiben-Sicherheitsgläser nie nachträglich bearbeiten.

GB Safety information:
Single-pane, safety glass panels must not be reworked in any way following supply.

F Remarques concernant la sécurité:
Vous ne devez en aucune façon tenter de retailer les vitrages en verre sécurité.

NL Veiligheidsvoorschrift:
Gehard veiligheidsglas mag niet achteraf worden bewerkt.

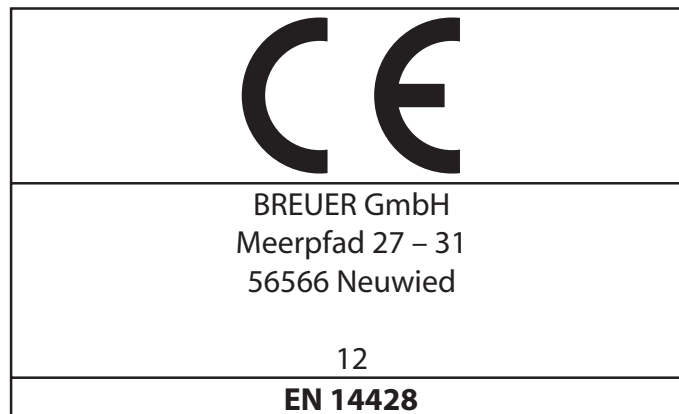

D	Duschabtrennung aus einem bestimmten Scheibenmaterial
Reinigbarkeit:	Bestanden
Brucheigenschaften:	Bestanden
Dauerhaftigkeit:	Bestanden

F	Paroi de douche dans un matériau vitré particulier
Nettoyabilité:	passé avec succès
Propriétés à la cassure:	passé avec succès
Durabilité:	passé avec succès

GB	Shower enclosure made of a specific pane material
Cleanability:	Passed
Fracture behaviour:	Passed
Durability:	Passed

NL	Douche-afschieding van bepaald ruitmateriaal
Reinigbaarheid:	Doorstaan
Bruekeigenschappen:	Doorstaan
Duurzaamheid:	Doorstaan